

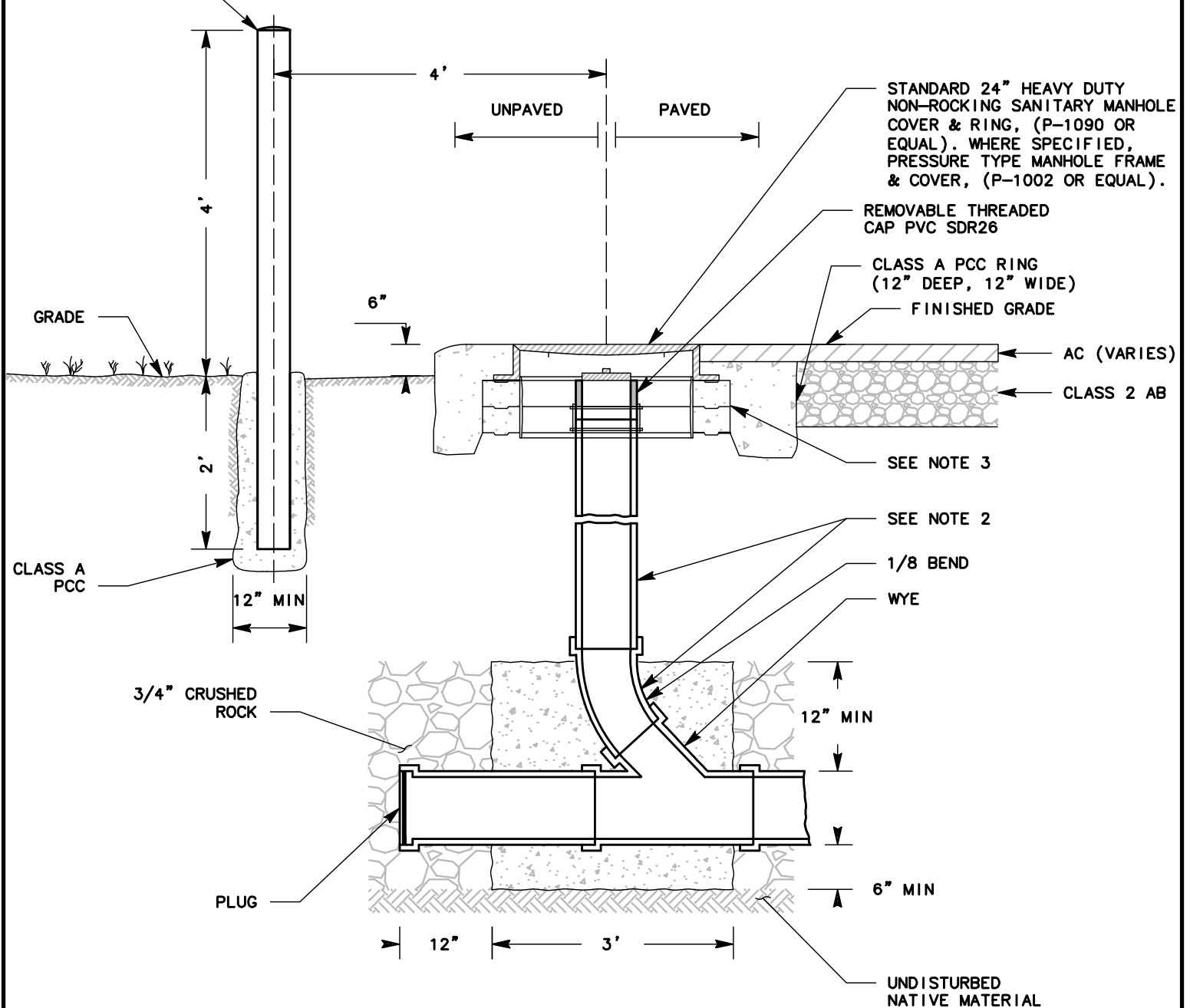

# COUNTY SANITATION DISTRICT NO. 2-3

MARKER POST. 4"  
SCH40 STEEL PIPE  
6' LONG FILLED  
WITH CONCRETE



## NOTES:

1. REFER TO STANDARD DETAIL NO.1 FOR TRENCH SECTIONS
2. RISER & 1/8 BEND TO BE SAME SIZE AS EXISTING MAIN. PVC SDR26, OR APPROVED EQUAL. PRIOR WRITTEN APPROVAL BY DISTRICT ENGINEER REQUIRED FOR ALL SUBSTITUTIONS OF MATERIALS OR CONFIGURATION.
3. 3" ADJUSTING RINGS. MAXIMUM 2, UNLESS OTHERWISE DIRECTED BY DISTRICT ENGINEER.

# FLUSHING INLET

DETAIL **5**

DR. BY: ED  
DATE: 06/01/2020

CK. BY: FQ  
DATE: 06/01/2020

APPROVED. BY:

DATE: 06/01/2020